

Information in this drawing is of a general nature. Detailed design information (part thickness, load ratings, etc.) are not part of this drawing. User should consult the manufacturer of the pipe support for detailed design information and proper selection of the pipe support for the application.

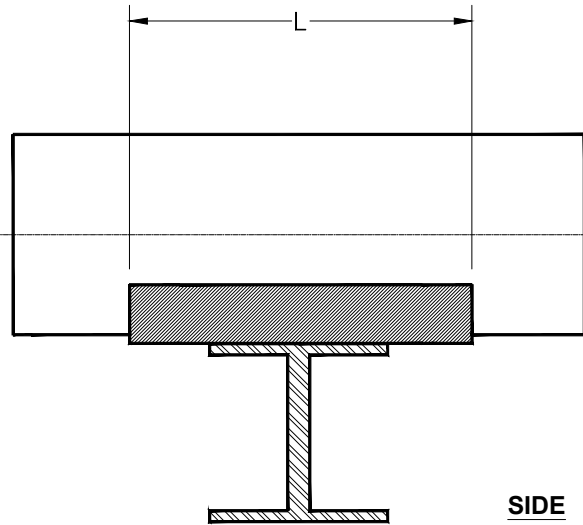

SIDE

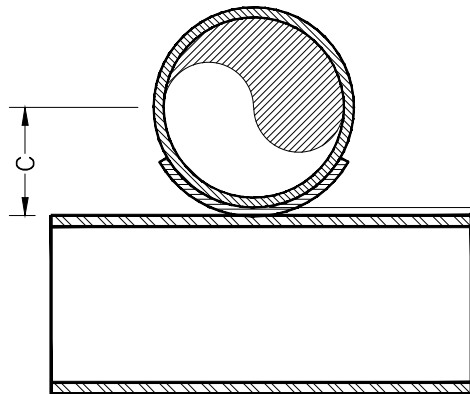

ELEV

0.20 to 0.32" (5 to 8mm) up to 24"Ø
 0.32 to 0.42" (8 to 10.5mm) 26" to 60"Ø

Nominal Pipe Size	Nominal O.D.		C		L		Minimum L		Weight (lb/kg)	
SERIES 20HV, 20FRE, 20FRE-C										
1" (DN25)	1.50"	38mm	1.06"	27mm	6"	152mm	4"	102mm	0.4	0.2
1.5" (DN40)	2.00"	51mm	1.31"	33mm	6"	152mm	4"	102mm	0.5	0.2
2" (DN50)	2.50"	64mm	1.56"	40mm	6"	152mm	4"	102mm	0.7	0.3
3" (DN80)	3.50"	89mm	2.00"	51mm	6"	152mm	4"	102mm	1.0	0.5
4" (DN100)	4.50"	114mm	2.50"	64mm	6"	152mm	4"	102mm	1.3	0.6
6" (DN150)	6.63"	168mm	3.56"	90mm	8"	203mm	4"	102mm	2.6	1.2
8" (DN200)	8.75"	222mm	4.63"	117mm	10"	254mm	4"	102mm	4.2	1.9
10" (DN250)	10.88"	276mm	5.69"	144mm	12"	305mm	4"	102mm	6.3	2.9
12" (DN300)	13.00"	330mm	6.75"	171mm	12"	305mm	4"	102mm	7.5	3.4
14" (DN350)	15.13"	384mm	7.81"	198mm	12"	305mm	4"	102mm	8.9	4.0
16" (DN400)	17.25"	438mm	8.88"	225mm	12"	305mm	4"	102mm	10.1	4.6
18" (DN450)	19.38"	492mm	9.94"	252mm	16"	406mm	6"	152mm	15.1	6.9
20" (DN500)	21.50"	546mm	11.00"	279mm	16"	406mm	6"	152mm	16.7	7.6
24" (DN600)	25.75"	654mm	13.13"	333mm	16"	406mm	6"	152mm	20.0	9.1
30" (DN750)	31.50"	800mm	16.13"	410mm	20"	508mm	8"	203mm	46.9	21.3
36" (DN900)	37.75"	959mm	19.25"	489mm	20"	508mm	8"	203mm	56.1	25.5
42" (DN1050)	43.13"	1096mm	21.94"	557mm	24"	610mm	10"	254mm	78.3	35.6
48" (DN1200)	49.25"	1251mm	25.00"	635mm	24"	610mm	10"	254mm	89.4	40.6
54" (DN1350)										
60" (DN1500)	61.50"	1562mm	31.13"	791mm	24"	610mm	10"	254mm	111.4	50.6

- NOTE 4. $C = 0.5 * \text{Nominal O.D.} + \text{Pad Thk}$ (0.25" nom. up to 24"Ø, 0.38" above 24"Ø).
- NOTE 3. Wear pad to be centered on structural support.
- NOTE 2. Wear pad to have minimum 120 degrees of contact (max. 180 degrees).
- NOTE 1. Wear pad to be of the same material as the pipe.

This print and its contents are the property of Future Pipe Industries. Use of print or its contents is prohibited unless authorized in writing. This information is subject to the controls of the Export Administration Regulations (EAR). Diversion contrary to US Law is strictly prohibited.

FIBERBOND[®]
 ENGINEERED COMPOSITE PIPING SYSTEMS
 Manufactured by Future Pipe Industries
www.fiberbond.com Baton Rouge, LA, U.S.A.

FRP "WEAR" PAD
 FIG.210 - 20FRE

REV: 5

Information in this drawing is of a general nature. Detailed design information (part thickness, load ratings, etc.) are not part of this drawing. User should consult the manufacturer of the pipe support for detailed design information and proper selection of the pipe support for the application.

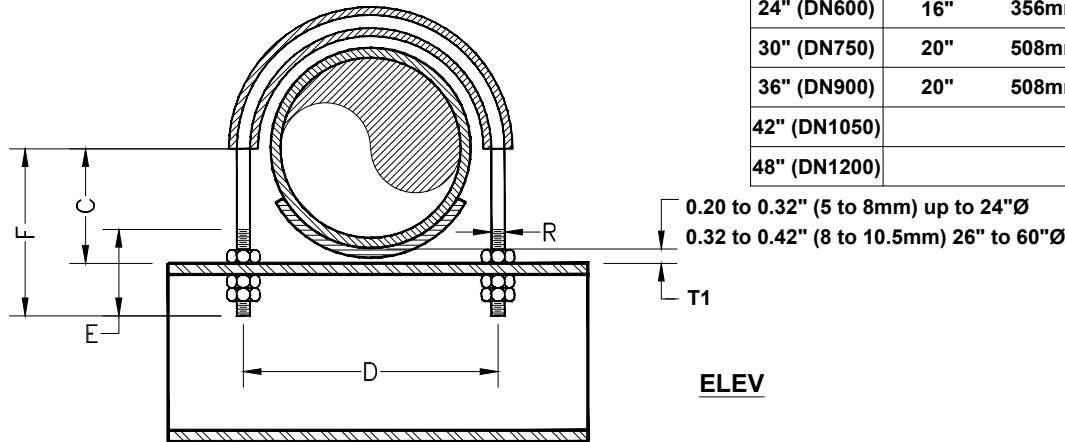
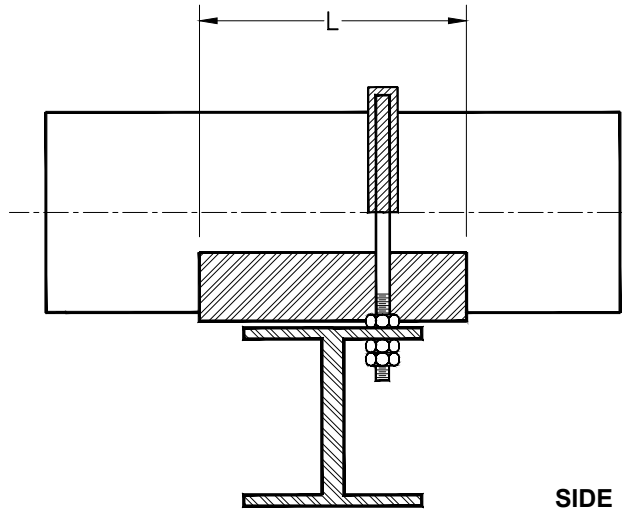

Nominal Pipe Size	L		R	D +/- 0.12"		E		F	
SERIES 20HV, 20FR-E, 20FR16, 20FR20, 20JF, 20JF16, 110FW, 20C, 20HV-D									
SERIES 20HV-C, 20FR-EC, 20FR16-C, 20FR20-C, 20JF-C, 20JF16-C, 20HV(FDA)									
1" (DN25)	6"	152mm	3/8"	3.25"	83mm	3.00"	76mm	2.75"	70mm
1.5" (DN40)	6"	152mm	3/8"	3.75"	95mm	3.00"	76mm	3.00"	76mm
2" (DN50)	6"	152mm	3/8"	4.25"	108mm	3.00"	76mm	3.25"	83mm
3" (DN80)	6"	152mm	1/2"	5.25"	133mm	3.50"	89mm	4.13"	105mm
4" (DN100)	6"	152mm	1/2"	6.25"	159mm	3.50"	89mm	4.63"	118mm
6" (DN150)	8"	203mm	5/8"	8.38"	213mm	4.00"	102mm	6.06"	154mm
8" (DN200)	10"	254mm	5/8"	10.38"	264mm	4.00"	102mm	7.13"	181mm
10" (DN250)	12"	305mm	3/4"	12.50"	317mm	4.50"	114mm	8.56"	217mm
12" (DN300)	12"	305mm	7/8"	14.75"	375mm	5.00"	127mm	10.00"	254mm
14" (DN350)	12"	305mm	7/8"	16.95"	430mm	5.00"	127mm	11.23"	285mm
16" (DN400)	12"	305mm	7/8"	19.11"	485mm	5.00"	127mm	12.31"	313mm
18" (DN450)	16"	356mm	1"	21.42"	544mm	5.50"	140mm	13.77"	350mm
20" (DN500)	16"	356mm	1"	23.38"	594mm	5.50"	140mm	14.75"	375mm
24" (DN600)	16"	356mm	1"	27.68"	703mm	5.50"	140mm	16.90"	429mm
30" (DN750)	20"	508mm	1"	33.78"	858mm	5.50"	140mm	19.72"	501mm
36" (DN900)	20"	508mm	1"	40.06"	1018mm	5.50"	140mm	22.86"	581mm
42" (DN1050)									
48" (DN1200)									

0.20 to 0.32" (5 to 8mm) up to 24"Ø
 0.32 to 0.42" (8 to 10.5mm) 26" to 60"Ø

- NOTE 11. An "extra-long" L dimension of 14" (356mm) may be used up to 16"Ø.
- NOTE 10. Minimum L dimensions per Fig.210 may also be used.
- NOTE 9. $F = C + 1/2in. + 3 * R$ (or use values in table).
- NOTE 8. $E = 4 * R + 1 1/2in.$
- NOTE 7. $C = 0.5 * Avg\ O.D. + T1$ (See Fig.210 for C dimensions).
- NOTE 6. $D = Pipe\ O.D. + 2 * T1 + R + 1/4in.$ (or use values in table).
- NOTE 5. T1 dimension is from T.O.S. to B.O.P.
- NOTE 4. The u-bolt shall not "anchor" the pipe.
- NOTE 3. Wear pad to be centered on structural support.
- NOTE 2. Wear pad to have minimum 120 degrees of contact (max. 180 degrees).
- NOTE 1. Saddle to be of the same material as the pipe.

Rev 12 Changes: Increased "D" dimension in sizes 1" thru 2" by 0.5", in sizes 3" & 4" by 3/8", in size 6" by 1/4" and in size 8" by 1/8". No other changes.

FIBERBOND®
 ENGINEERED COMPOSITE PIPING SYSTEMS
 Manufactured by Future Pipe Industries
 www.fiberbond.com Baton Rouge, LA, U.S.A.

This print and its contents are the property of Future Pipe Industries. Use of print or its contents is prohibited unless authorized in writing. This information is subject to the controls of the Export Administration Regulations (EAR). Diversion contrary to US Law is strictly prohibited.

RUBBER COATED U-BOLT
 FIG.226 - GENERAL DETAIL

REV: 12

Information in this drawing is of a general nature. Detailed design information (part thickness, load ratings, etc.) are not part of this drawing. User should consult the manufacturer of the pipe support for detailed design information and proper selection of the pipe support for the application.

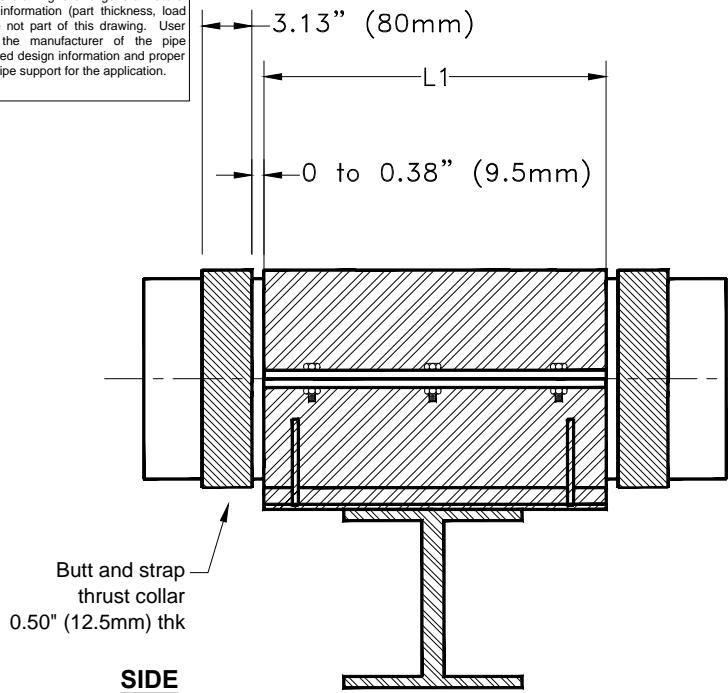

Nominal Pipe Size	Nominal O.D.		L1		C		E	
SERIES 20HV, 20FRE, 20FRE-C								
6" (DN150)	6.63"	168mm	8"	203mm	4.95"	126mm	12.00"	305mm
8" (DN200)	8.75"	222mm	10"	254mm	6.00"	152mm	14.00"	356mm
10" (DN250)	10.88"	276mm	12"	305mm	7.07"	180mm	16.00"	406mm
12" (DN300)	13.00"	330mm	12"	305mm	8.13"	207mm	18.00"	458mm
14" (DN350)	15.13"	384mm	12"	305mm	9.20"	234mm	20.25"	514mm
16" (DN400)	17.25"	438mm	12"	305mm	10.26"	261mm	22.25"	565mm
18" (DN450)	19.38"	492mm	16"	406mm	11.32"	288mm	24.50"	622mm
20" (DN500)	21.50"	546mm	16"	406mm	12.38"	314mm	26.50"	673mm
24" (DN600)	25.75"	654mm	16"	406mm	14.51"	369mm	30.75"	781mm
30" (DN750)	31.50"	800mm	20"	508mm	17.38"	441mm	37.25"	946mm
36" (DN900)	37.75"	959mm	20"	508mm	20.51"	521mm	43.50"	1105mm
42" (DN1050)	43.13"	1096mm	24"	610mm	23.20"	589mm	49.50"	1257mm
48" (DN1200)	49.25"	1251mm	24"	610mm	26.26"	667mm	56.00"	1422mm
54" (DN1350)								
60" (DN1500)	61.50"	1562mm	24"	610mm	32.38"	822mm	68.00"	1727mm

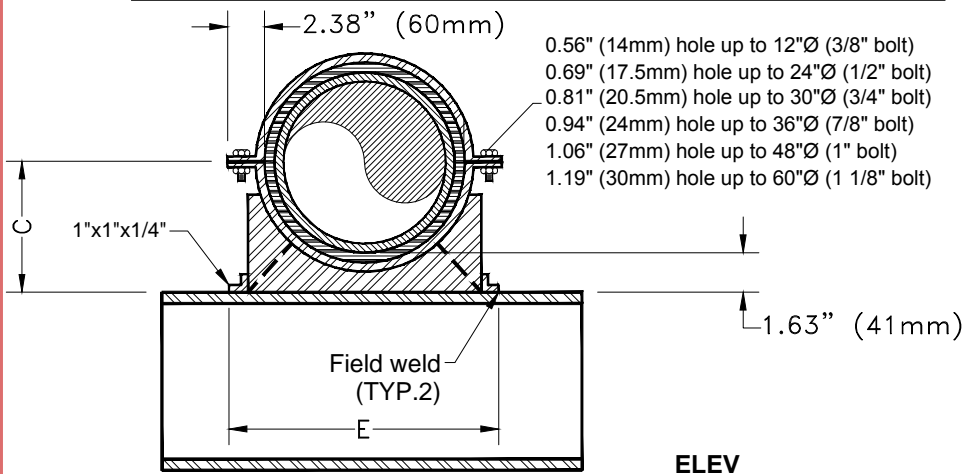

NOTE 5. Average O.D. is typically 0.03" to 0.10" larger than the nominal O.D.
 NOTE 4. C = 0.5 * Nominal O.D. + 1.63in.
 NOTE 3. Steel saddle includes 1/8in. thick neoprene liner.
 NOTE 2. 1.63in. (41mm) dimension is from T.O.S to B.O.P.
 NOTE 1. Thrust collar may need to be larger depending upon design conditions.

This print and its contents are the property of Future Pipe Industries. Use of print or its contents is prohibited unless authorized in writing. This information is subject to the controls of the Export Administration Regulations (EAR). Diversion contrary to US Law is strictly prohibited.

FIBERBOND®
 ENGINEERED COMPOSITE PIPING SYSTEMS
 Manufactured by Future Pipe Industries
 www.fiberbond.com Baton Rouge, LA, U.S.A.

STEEL ANCHOR
 FIG.230 - 20FRE

REV: 1

Information in this drawing is of a general nature. Detailed design information (part thickness, load ratings, etc.) are not part of this drawing. User should consult the manufacturer of the pipe support for detailed design information and proper selection of the pipe support for the application.

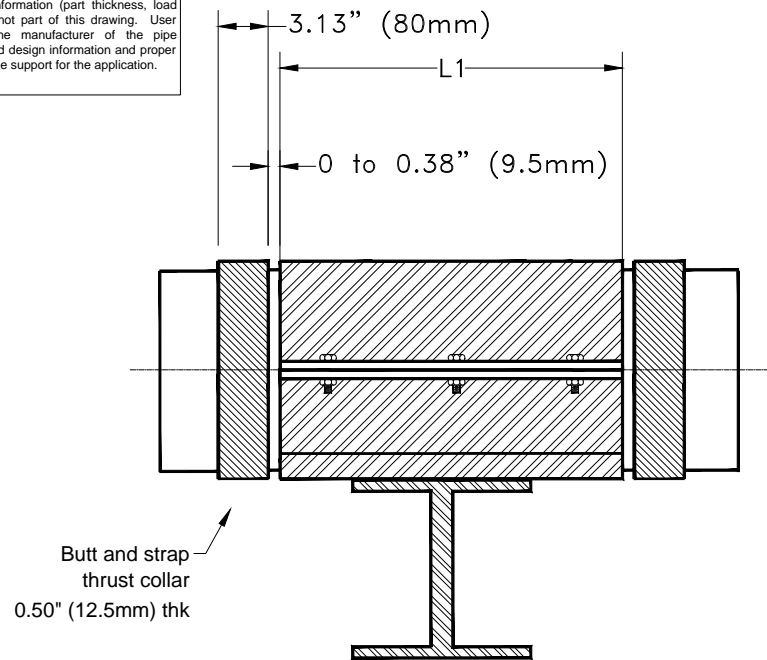

SIDE

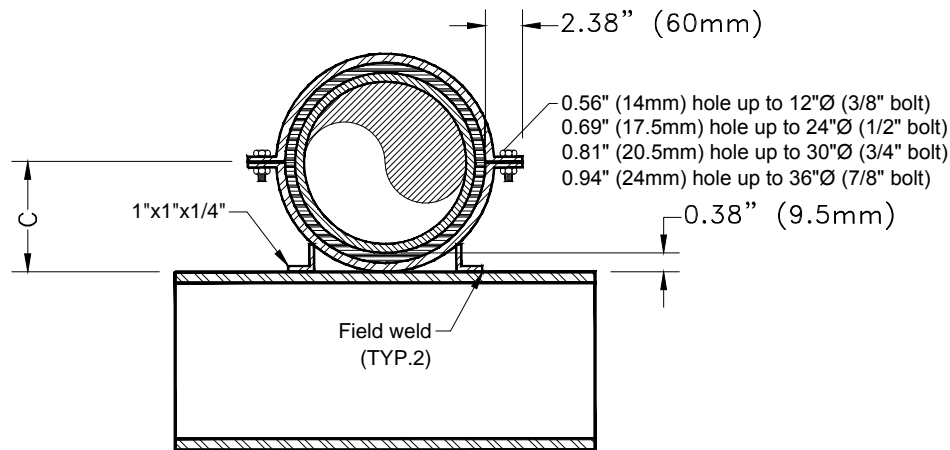

ELEV

- NOTE 5. Average O.D. is typically 0.03" to 0.10" larger than the nominal O.D.
 NOTE 4. $C = 0.5 * \text{Nominal O.D.} + 0.38\text{in.}$
 NOTE 3. Steel saddle includes 1/8in. thick neoprene liner.
 NOTE 2. 0.38in. (9.5mm) dimension is from T.O.S. to B.O.P.
 NOTE 1. Thrust collar may need to be larger depending upon design conditions.

Nominal Pipe Size	Nominal O.D.		L1		C	
SERIES 20HV, 20FRE, 20FRE-C						
2" (DN50)	2.50"	64mm	6"	152mm	1.63"	41mm
3" (DN80)	3.50"	89mm	6"	152mm	2.13"	54mm
4" (DN100)	4.50"	114mm	6"	152mm	2.63"	67mm
6" (DN150)	6.63"	168mm	8"	203mm	3.70"	94mm
8" (DN200)	8.75"	222mm	10"	254mm	4.76"	121mm
10" (DN250)	10.88"	276mm	12"	305mm	5.82"	148mm
12" (DN300)	13.00"	330mm	12"	305mm	6.88"	175mm
14" (DN350)	15.13"	384mm	12"	305mm	7.95"	202mm
16" (DN400)	17.25"	438mm	12"	305mm	9.00"	229mm
18" (DN450)	19.38"	492mm	12"	305mm	10.06"	256mm
20" (DN500)	21.50"	546mm	16"	406mm	11.12"	283mm
24" (DN600)	25.75"	654mm	16"	406mm	13.25"	337mm
30" (DN750)	31.50"	800mm	20"	508mm	16.13"	410mm
36" (DN900)	37.75"	959mm	20"	508mm	19.25"	489mm
42" (DN1050)	43.13"	1096mm				
48" (DN1200)	49.25"	1251mm				
54" (DN1350)						
60" (DN1500)	61.50"	1562mm				

FIBERBOND®
 ENGINEERED COMPOSITE PIPING SYSTEMS
 Manufactured by Future Pipe Industries
www.fiberbond.com Baton Rouge, LA, U.S.A.

This print and its contents are the property of Future Pipe Industries. Use of print or its contents is prohibited unless authorized in writing. This information is subject to the controls of the Export Administration Regulations (EAR). Diversion contrary to US Law is strictly prohibited.

SMALL STEEL ANCHOR
 FIG.232 - 20FRE

REV: 2

Information in this drawing is of a general nature. Detailed design information (part thickness, load ratings, etc.) are not part of this drawing. User should consult the manufacturer of the pipe support for detailed design information and proper selection of the pipe support for the application.

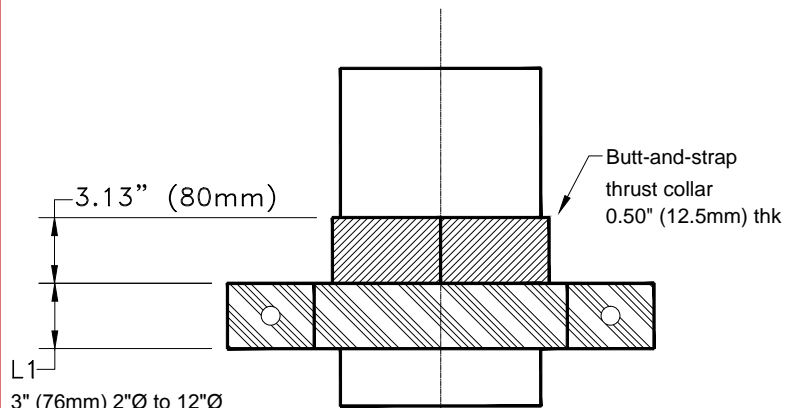

3" (76mm) 2"Ø to 12"Ø
 5" (127mm) 14"Ø to 16"Ø
 6" (152mm) 18"Ø to 30"Ø
 8" (203mm) 36"Ø to 42"Ø
 9" (229mm) 48"Ø to 60"Ø

ELEV

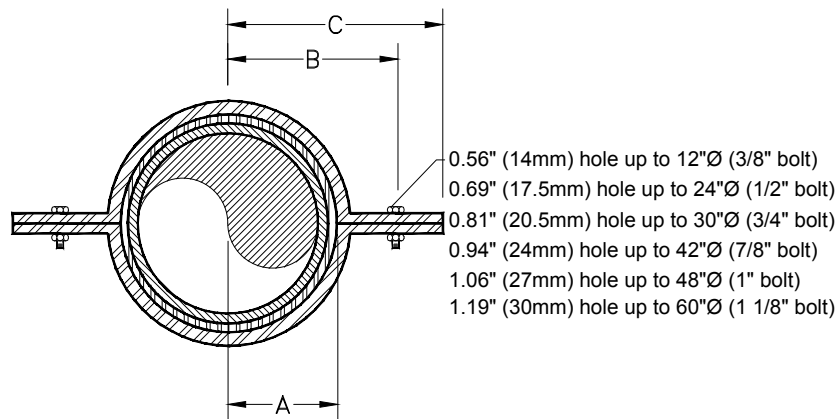

PLAN

NOTE 5. 'A' dimension is from pipe centerline to neoprene/steel interface.

NOTE 4. $A = 0.5 * \text{Nominal O.D.} + 0.13\text{in.}$

NOTE 3. $B = 0.5 * \text{Nominal O.D.} + 1.75\text{in.}; C = B + 1.25\text{in.}$

NOTE 2. Steel saddle includes 1/8in. thick neoprene liner.

NOTE 1. A separate bonded collar (two halves) may also be used.

Nominal Pipe Size	Nominal O.D.		A		B		C	
SERIES 20HV, 20FRE, 20FRE-C								
2" (DN50)	2.50"	64mm	1.38"	35mm	3.00"	76mm	4.25"	108mm
3" (DN80)	3.50"	89mm	1.88"	48mm	3.50"	89mm	4.75"	121mm
4" (DN100)	4.50"	114mm	2.38"	60mm	4.00"	102mm	5.25"	133mm
6" (DN150)	6.63"	168mm	3.44"	88mm	5.06"	129mm	6.31"	160mm
8" (DN200)	8.75"	222mm	4.50"	114mm	6.13"	156mm	7.38"	187mm
10" (DN250)	10.88"	276mm	5.57"	141mm	7.19"	183mm	8.44"	214mm
12" (DN300)	13.00"	330mm	6.63"	168mm	8.25"	210mm	9.50"	241mm
14" (DN350)	15.13"	384mm	7.69"	195mm	9.32"	237mm	10.57"	268mm
16" (DN400)	17.25"	438mm	8.75"	222mm	10.38"	264mm	11.63"	295mm
18" (DN450)	19.38"	492mm	9.82"	249mm	11.44"	291mm	12.69"	322mm
20" (DN500)	21.50"	546mm	10.88"	276mm	12.50"	317mm	13.75"	349mm
24" (DN600)	25.75"	654mm	13.00"	330mm	14.63"	372mm	15.88"	403mm
30" (DN750)	31.50"	800mm	15.88"	403mm	17.50"	444mm	18.75"	476mm
36" (DN900)	37.75"	959mm	19.00"	483mm	20.63"	524mm	21.88"	556mm
42" (DN1050)	43.13"	1096mm	21.69"	551mm	23.32"	592mm	24.57"	624mm
48" (DN1200)	49.25"	1251mm	24.75"	629mm	26.38"	670mm	27.63"	702mm
54" (DN1350)								
60" (DN1500)	61.50"	1562mm	30.88"	784mm	32.50"	826mm	33.75"	857mm

0.56" (14mm) hole up to 12"Ø (3/8" bolt)
 0.69" (17.5mm) hole up to 24"Ø (1/2" bolt)
 0.81" (20.5mm) hole up to 30"Ø (3/4" bolt)
 0.94" (24mm) hole up to 42"Ø (7/8" bolt)
 1.06" (27mm) hole up to 48"Ø (1" bolt)
 1.19" (30mm) hole up to 60"Ø (1 1/8" bolt)

FIBERBOND®
 ENGINEERED COMPOSITE PIPING SYSTEMS
 Manufactured by Future Pipe Industries
www.fiberbond.com Baton Rouge, LA, U.S.A.

This print and its contents are the property of Future Pipe Industries. Use of print or its contents is prohibited unless authorized in writing. This information is subject to the controls of the Export Administration Regulations (EAR). Diversion contrary to US Law is strictly prohibited.

STEEL RISER CLAMP
 FIG.240 - 20FRE

REV: 2

Information in this drawing is of a general nature. Detailed design information (part thickness, load ratings, etc.) are not part of this drawing. User should consult the manufacturer of the pipe support for detailed design information and proper selection of the pipe support for the application.

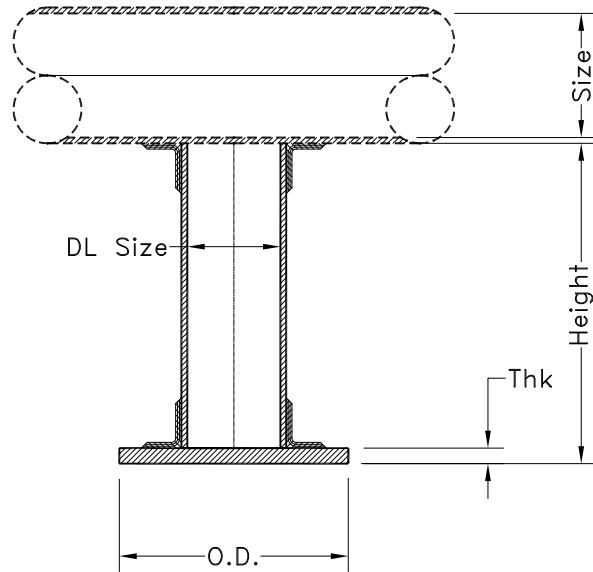

FIG.91 (shop fab'd to a tee or pipe)

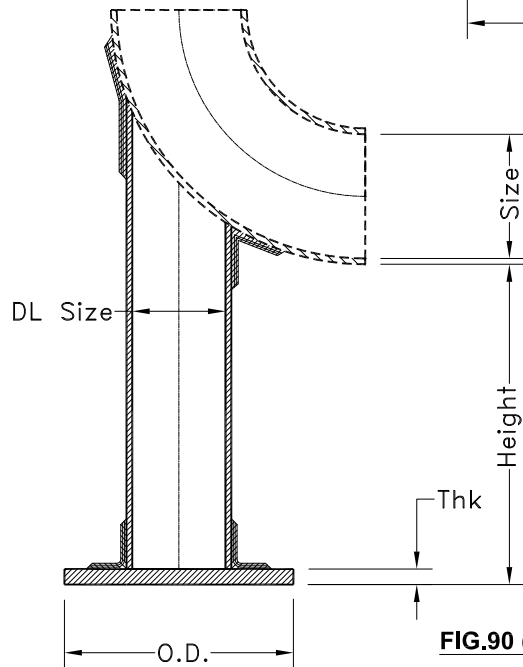

FIG.90 (shop fab'd to an elbow)

Nominal Pipe Size	DL Size	O.D.	Thk
2" (DN50)	2"	5" 127mm	1/2" 12.5mm
3" (DN80)	2"	5" 127mm	1/2" 12.5mm
4" (DN100)	3"	6" 152mm	1/2" 12.5mm
5" (DN125)	3"	6" 152mm	1/2" 12.5mm
6" (DN150)	4"	7" 178mm	1/2" 12.5mm
8" (DN200)	6"	9" 229mm	1/2" 12.5mm
10" (DN250)	6"	9" 229mm	1/2" 12.5mm
12" (DN300)	8"	12" 305mm	1/2" 12.5mm
14" (DN350)	10"	14" 356mm	1/2" 12.5mm
16" (DN400)	12"	16" 406mm	1/2" 12.5mm
18" (DN450)	14"	18" 457mm	1/2" 12.5mm
20" (DN500)	18"	22" 559mm	1/2" 12.5mm
24" (DN600)	18"	22" 559mm	1/2" 12.5mm
30" (DN750)	24"	28" 711mm	3/4" 19mm
36" (DN900)	24"	28" 711mm	3/4" 19mm
42" (DN1050)	36"	40" 1016mm	3/4" 19mm
48" (DN1200)	36"	40" 1016mm	3/4" 19mm
54" (DN1350)	48"	52" 1321mm	3/4" 19mm
60" (DN1500)	48"	52" 1321mm	3/4" 19mm

- NOTE 4. Fig.90 and Fig.91 are identical except Fig.91 is on a tee or pipe.
- NOTE 3. Maximum recommended length of dummy leg is 3'-0" (914mm).
- NOTE 2. Plate to be shipped loose and field installed. 6" of trim to be included.
- NOTE 1. Dummy leg to be of the same material as the pipe.

This print and its contents are the property of Future Pipe Industries. Use of print or its contents is prohibited unless authorized in writing. This information is subject to the controls of the Export Administration Regulations (EAR). Diversion contrary to US Law is strictly prohibited.

FIBERBOND®
 ENGINEERED COMPOSITE PIPING SYSTEMS
 Manufactured by Future Pipe Industries
 www.fiberbond.com Baton Rouge, LA, U.S.A.

FRP "DUMMY LEG"
 FIG.90 - GENERAL DETAIL

REV: 2